

**Gebrauchsanleitung PK-Nr. 3032**  
Instructions / Mode d'emploi / Gebruiksaanwijzing /  
инструкция по использованию

PAIDI Möbel GmbH  
Hauptstraße 87  
D-97840 Hafenlohr/Main

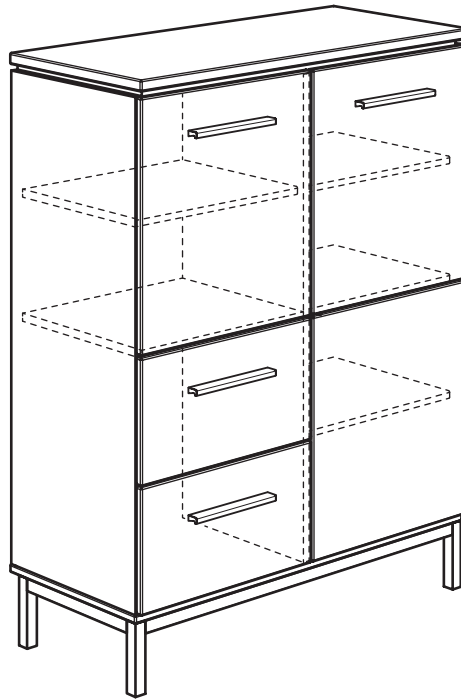

Kinderwelten



**BENNE**  
**129 5734**

**Seite 1 von 24**

PK-Nr. 3032 Stand 12/2019 Ä: 05/2020



[www.blauer-engel.de/uz38](http://www.blauer-engel.de/uz38)

- emissionsarm
- Holz aus nachhaltiger Forstwirtschaft
- in der Wohnumwelt gesundheitlich unbedenklich



GÜTEZEICHEN



Möbel

# Warnhinweis!

Warning notice! / Avertissement! / Waarschuwing! /  
Предупреждение!

PAIDI Möbel GmbH  
Hauptstraße 87  
D-97840 Hafenlohr/Main



Kinderwelten

V..

Vorbereitung / Preparation / La  
préparation/ Voorbereiding /  
подготовка

M..

Montage / Assembly /  
Assemblage / Bijeenkomst /  
МОНТАЖ

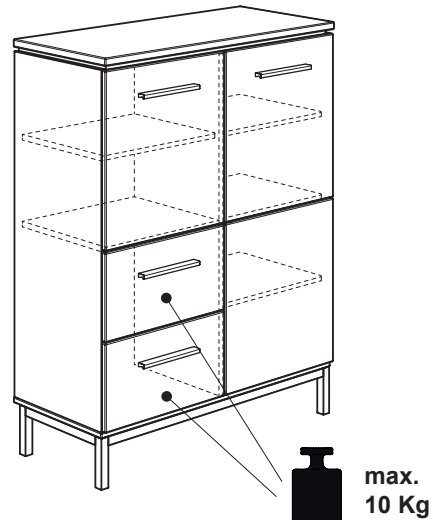
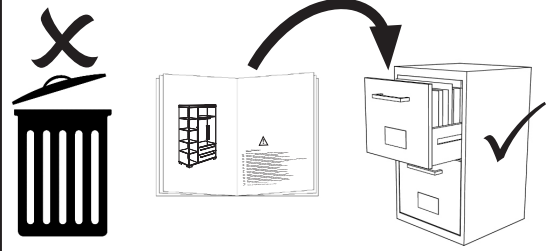

siehe PK-Nr. 2800

## Warnhinweis !

- DE Warnhinweis ! Beiliegende Wandbefestigungen müssen montiert werden !  
FR Attention ! Les fixations murales ci-jointes doivent être montées !  
GB Attention ! The enclosed wall mountings must be fitted !  
NL Let op ! De meegeleverde wandbevestigingen moeten worden gemonteerd !  
ES ¡Atención! Las fijaciones murales incluidas deben montarse  
GR Προσοχή ! Τα εξαρτήματα στήριξης που περιλαμβάνονται στη συσκευασία πρέπει να συναρμολογηθούν !  
IT Attenzione ! Occorre montare i fissaggi per attacco alla parete qui allegati !  
CZ Pozor ! Přiložené úchytky musí být namontovány na stěnu !  
SL Pozor ! Namontirati je potrebno priložene elemente za pritrditev na zid !  
PL Uwaga ! Załączone zamocowania do ściany muszą być zamontowane !  
BG Внимание ! Приложените закрепвания за стена трябва да бъдат монтирани !  
HR Pozor ! Priložena zidna pričvršćenja moraju biti montirana !  
LT Dėmesio ! Priededamas tvirtinimo prie sienos detales reikia sumontuoti !  
RU Внимание ! Обязательно используйте прилагаемые крепления стене !  
CN 注意！ 附带的墙壁安装组件必须安装！  
AR تنبه! لا بد من تركيب الأدوات المرفقة للتثبيت على الحائط!

- DE Pflegehinweis: Zum Reinigen der Oberflächen ein leicht-feuchtes Tuch oder ein handelsübliches Möbelpflegemittel verwenden.  
FR Indication sur l'entretien : pour nettoyer les surfaces, utiliser un chiffon légèrement humide ou un nettoyant pour meubles en vente dans le commerce  
GB Caring for the... : In order to clean the surfaces please use a slightly damp cloth or commercially available furniture care product.  
NL Verzorgingsanwijzing: Voor het reinigen van de oppervlakken een licht vochtig doek of een gebruikelijk meubelschoonmaakmiddel gebruiken.  
ES Recomendaciones de cuidado: Para limpiar las superficies del mueble debe usar un trapo humedecido o un producto de limpieza de muebles comercial.  
GR Οδηγίες περιποίησης: Για το καθάρισμα των επιφανειών να χρησιμοποιείτε ένα ελαφρά νοτισμένο πανάκι ή λούστρο επίπλων.  
IT Indicazione per pulizia e cura: Per la pulizia delle superfici utilizzate un panno leggermente umido o un normale prodotto per la cura dei mobili.  
CZ Pokyny k čištění: Na čištění povrchu použijte pouze navlhčený kousek látky nebo běžný prostředek na ošetřování nábytku.  
SL Navodilo za nego: Za čiščenje površin uporabljajte malo vlažno cunjo ali trgovsko običajno sredstvo za nego pohištva.  
PL Wskazówka pielęgnacyjna: do czyszczenia powierzchni stosować lekko wilgotną ściereczkę lub zwykły środek do pielęgnacji mebli.  
BG Указание за поддържане: Използвайте леко навлажнена кърпа или обикновен препарат за поддържане на мебели, за да почистите повърхностите.  
HR Upute za njegu: Za čišćenje površina upotrijebiti jednu lako navlaženu krpu i trgovačko uobičajeno sredstvo za njegu namještaja.  
LT Rekomendacija priežiūrai: Paviršius valykite drėgna pašluoste arba parduotuvėse įsigytomis baldų priežiūros priemonėmis.  
RU Рекомендации по уходу: для очистки поверхностей используйте слегка влажную тряпку или обычное средство по уходу за мебелью.  
CN 保养说明: 清洁表面只需用稍微潮湿的布或普通的家具清洁剂即可。

Seite 2 von 24

PK-Nr. 3032 Stand 12/2019 Ä: 05/2020

# Beschläge

Fittings / Raccords / Fittingen / кованый

PAIDI Möbel GmbH  
Hauptstraße 87  
D-97840 Hafenlohr/Main







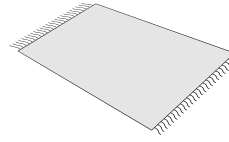
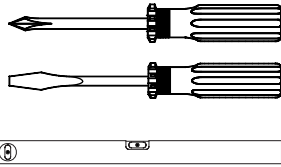
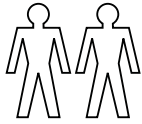
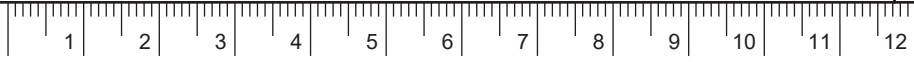



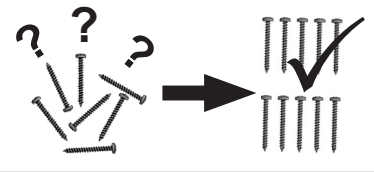



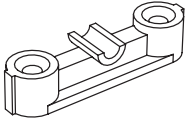

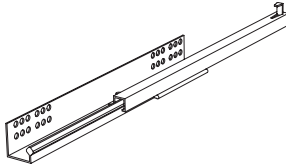
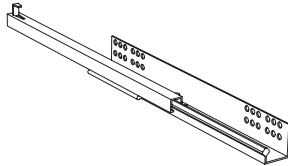
Kinderwelten

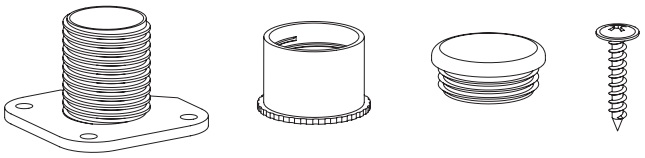
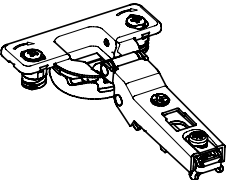
1:1  
DIN A4

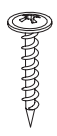

ca. 0,75h

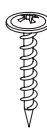
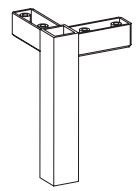

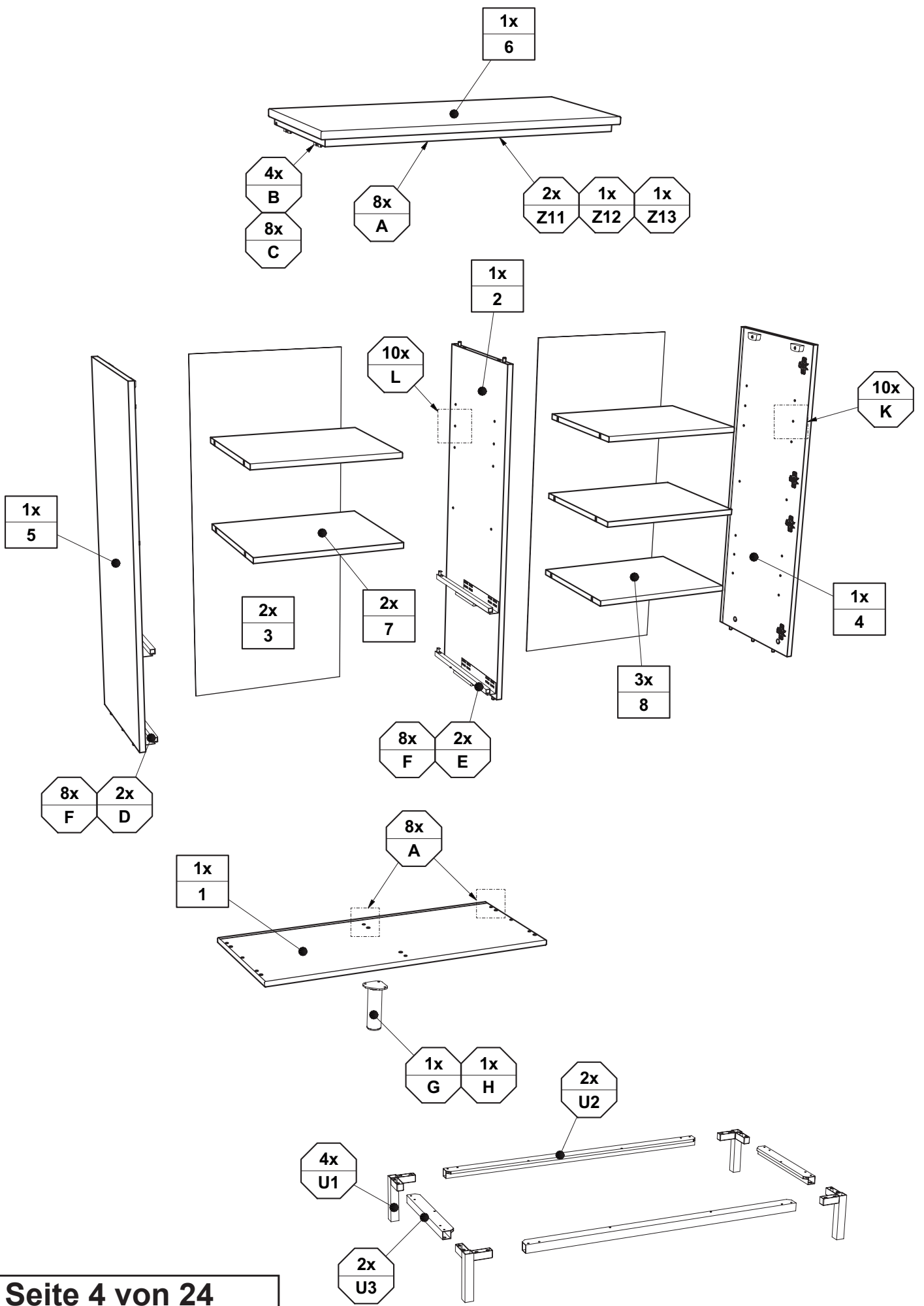

<p><b>A</b></p>  <p>8x 681 0759</p>	<p><b>B</b></p>  <p>4x 681 0886</p>	<p><b>C</b></p>  <p>3,5 x 20 8x 681 4888</p>	<p><b>D</b></p>  <p>2x 681 3316</p>	<p><b>E</b></p>  <p>2x 681 3317</p>	<p><b>F</b></p>  <p>6,3 x 14 8x 681 5097</p>	<p><b>G</b></p>  <p>1x 681 8533</p>		
<p><b>H</b></p>  <p>1x 1x 1x 3x 4,0 x 17</p>				<p><b>I</b></p>  <p>6x 681 2793</p>	<p><b>J</b></p>  <p>ø8 x 45 1x 681 0402</p>	<p><b>K</b></p>  <p>10x 681 8126</p>	<p><b>L</b></p>  <p>10x 681 8137</p>	
<p><b>M</b></p>  <p>8x 681 2498</p>	<p><b>N</b></p>  <p>3,0 x 20 5x 681 4914</p>	<p><b>O</b></p> <p>Griffstange Länge: 210mm</p> <p>4x 681 8518</p>	<p><b>P</b></p>  <p>4,0 x 30 8x 681 4910</p>	<p><b>S</b></p>  <p>4 x 35 16x 681 5001</p>	<p><b>T</b></p>  <p>4,0 x 20 6x 681 4917</p>	<p><b>U1</b></p>  <p>4x 681 8521</p>	<p><b>U2</b></p> <p>Sockelprofil Länge: 854mm</p> <p>2x 681 8524</p>	<p><b>U3</b></p> <p>Sockelprofil Länge: 302mm</p> <p>2x 681 8528</p>
<p><b>Z</b></p>  <p>6x 681 2552</p>		<p><b>X</b></p>  <p>Farbton Manhattan 6x 683 0102</p>						

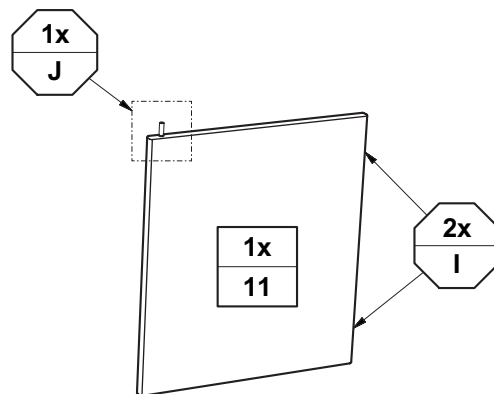
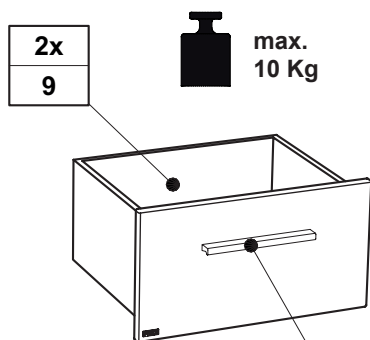
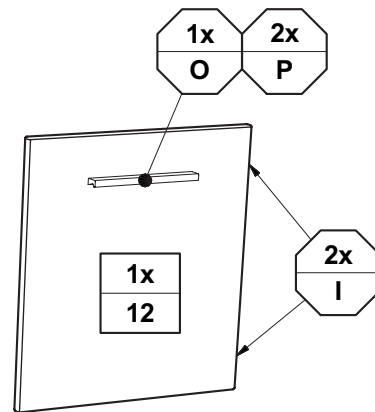
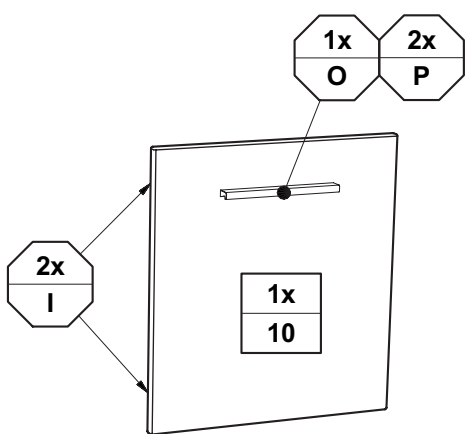

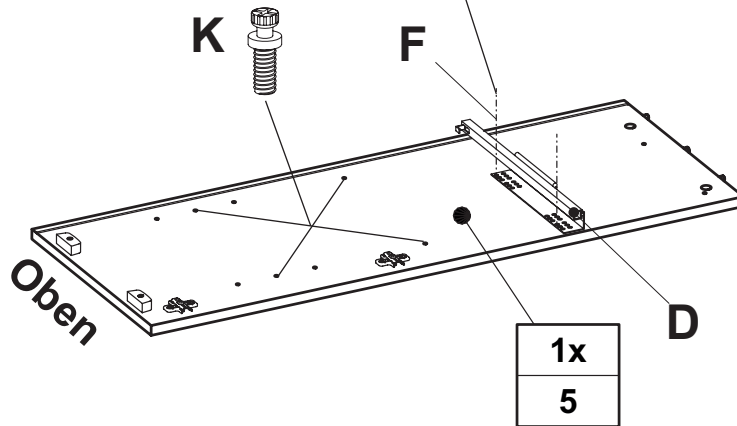
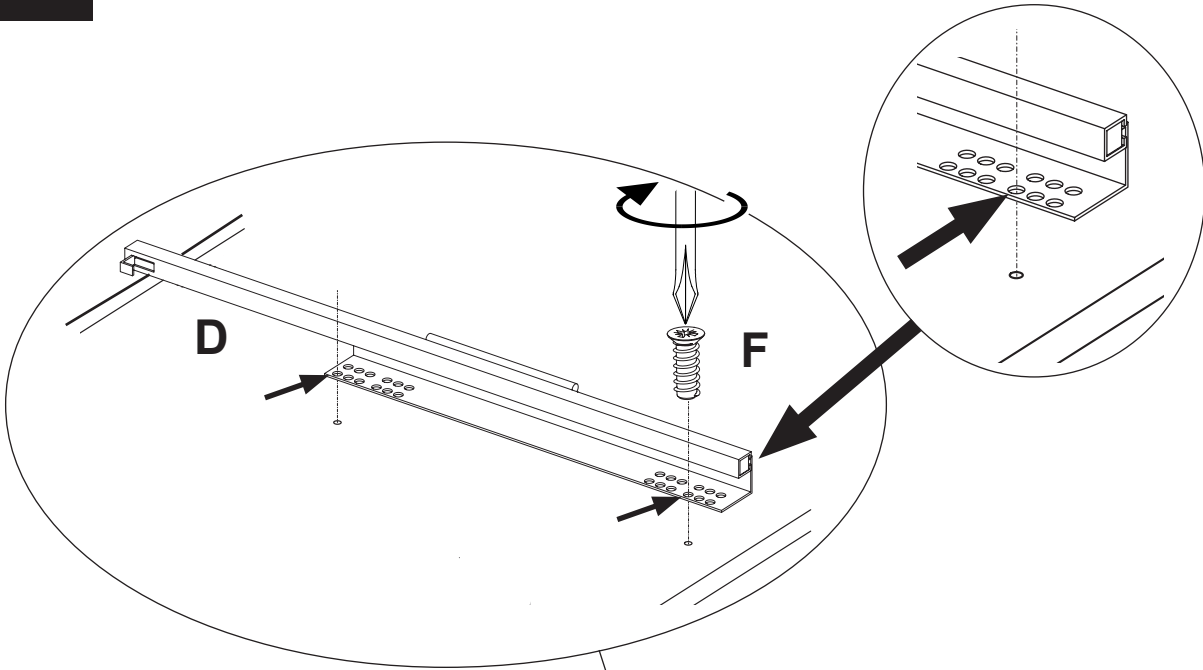



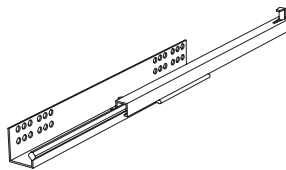

1x
5

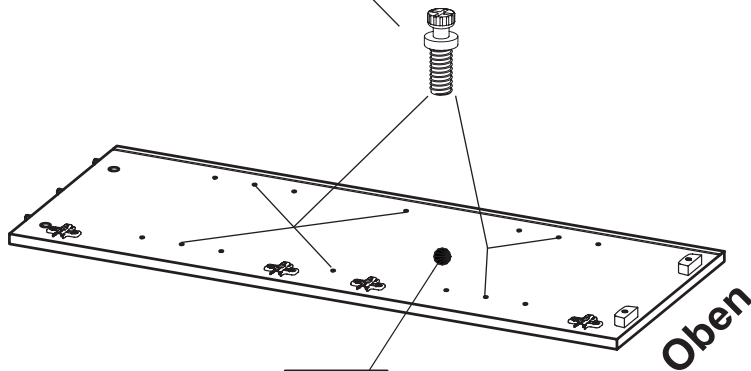
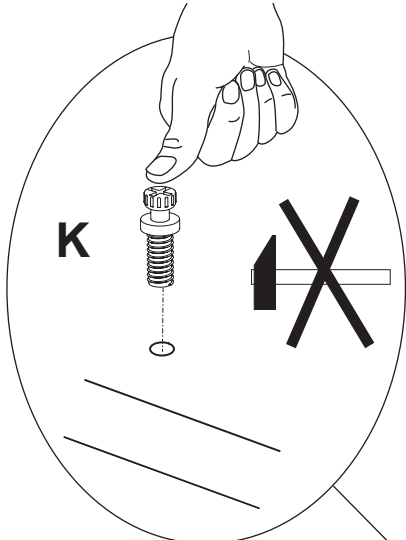
D	F	K
		
1x 681 3316	6,3 x 14 2x 681 5097	4x 681 8126



1x
4

**K**



6x  
681 8126

# V3

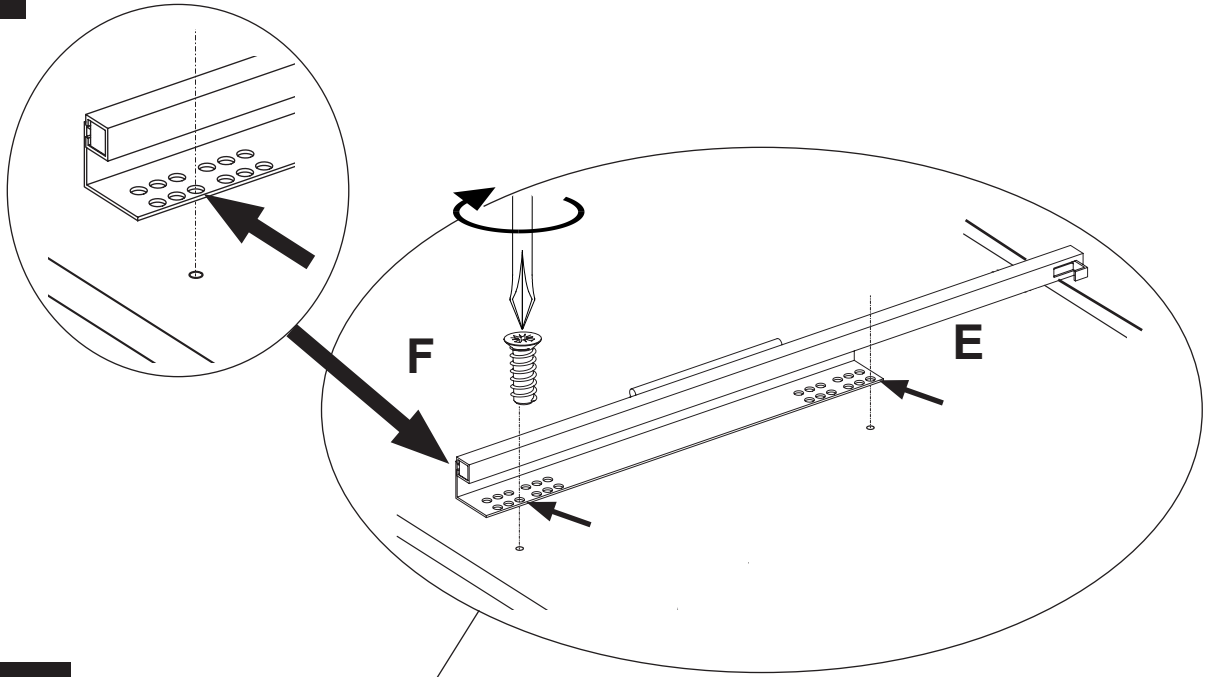

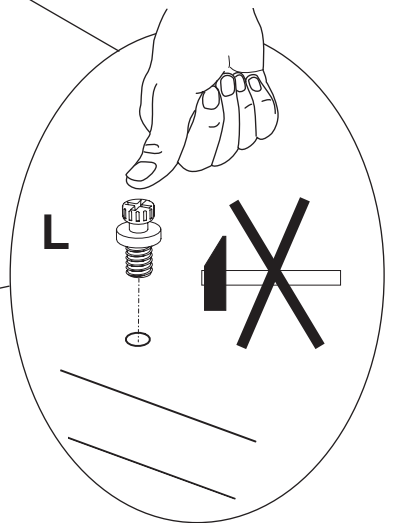
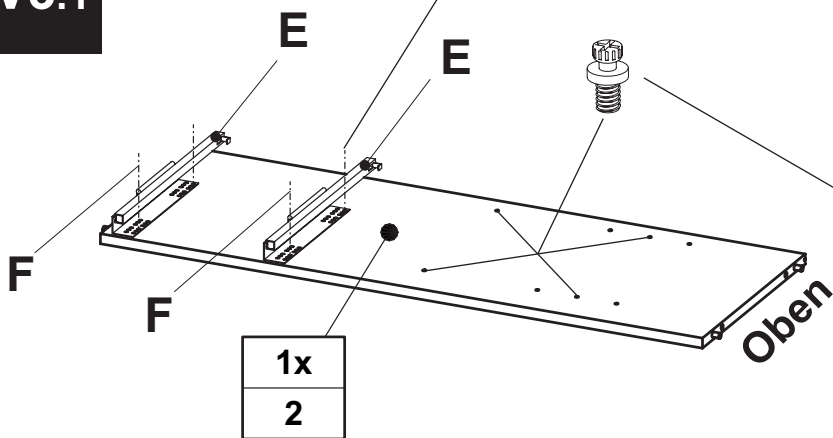

## V3.1

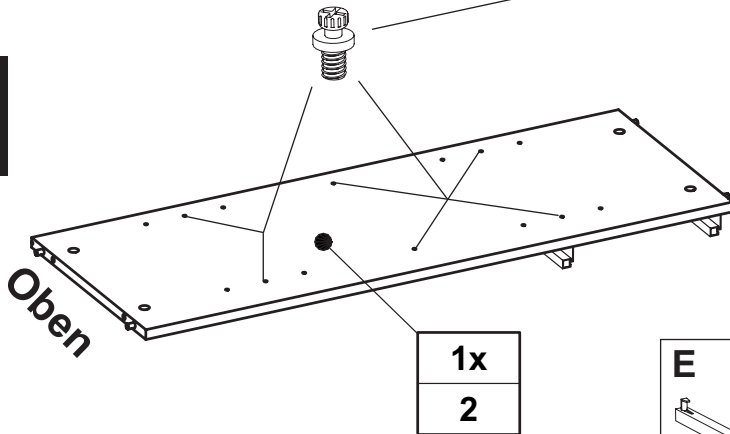

## V3.2

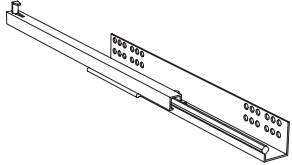

E	F	L
		
2x 681 3317	6,3 x 14 4x 681 5097	10x 681 8137



V4

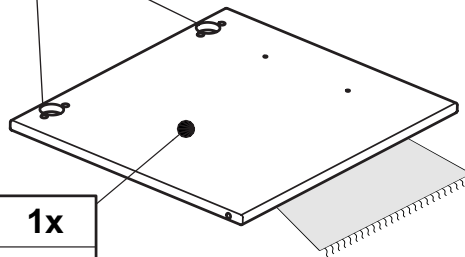
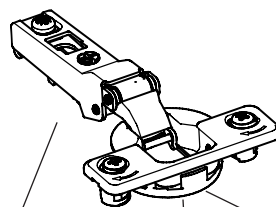

1x  
12

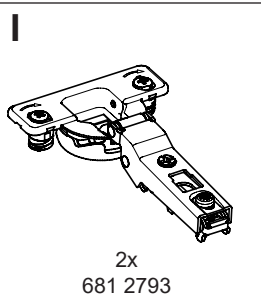

2x  
681 2793

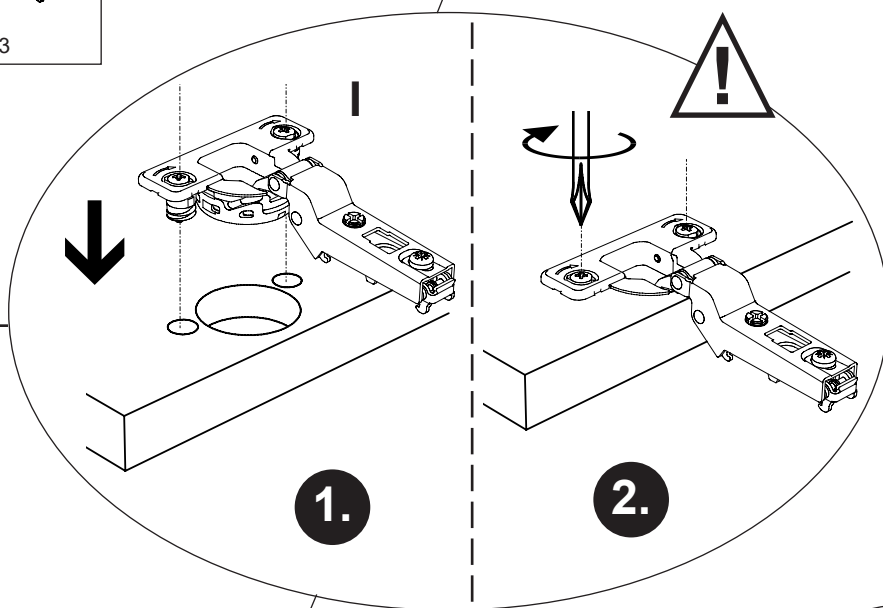

V5

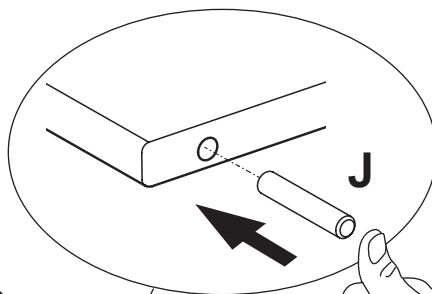

1x  
J

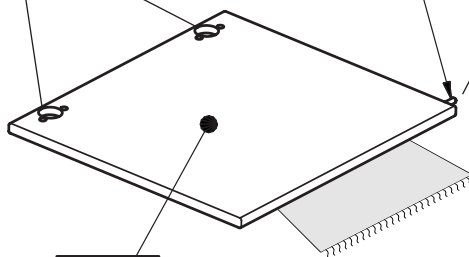
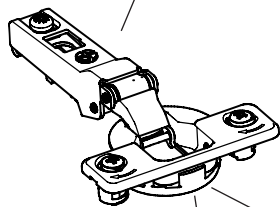

1x  
11



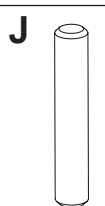

2x  
681 2793

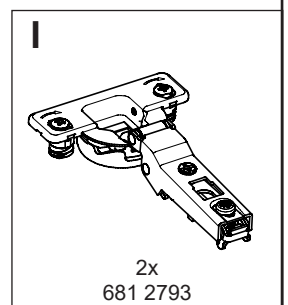
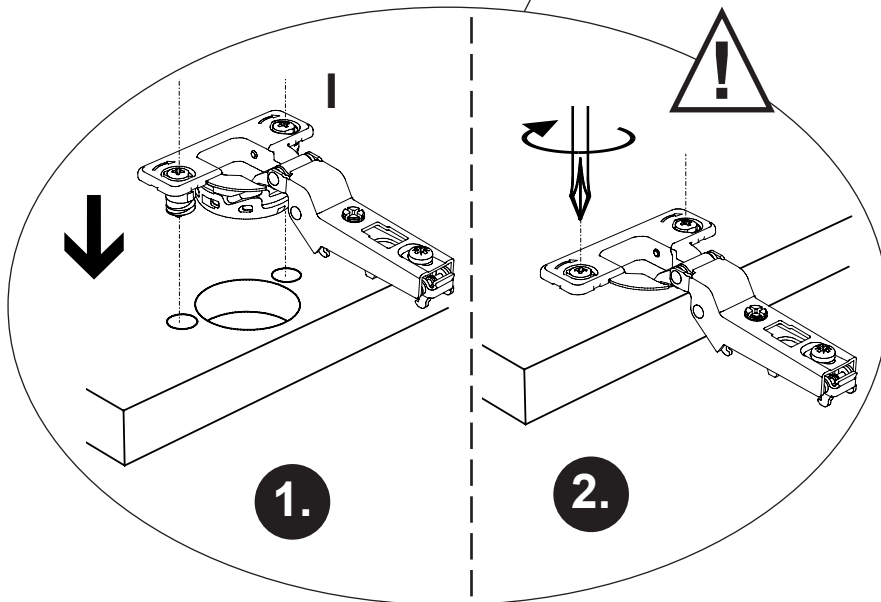
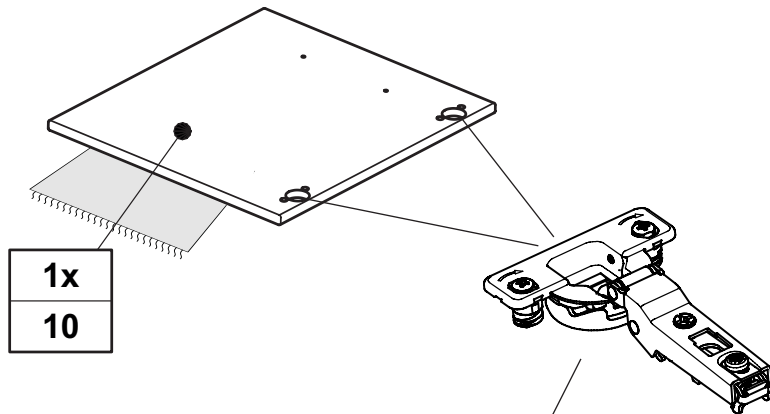

ø8 x 45  
1x  
681 0402

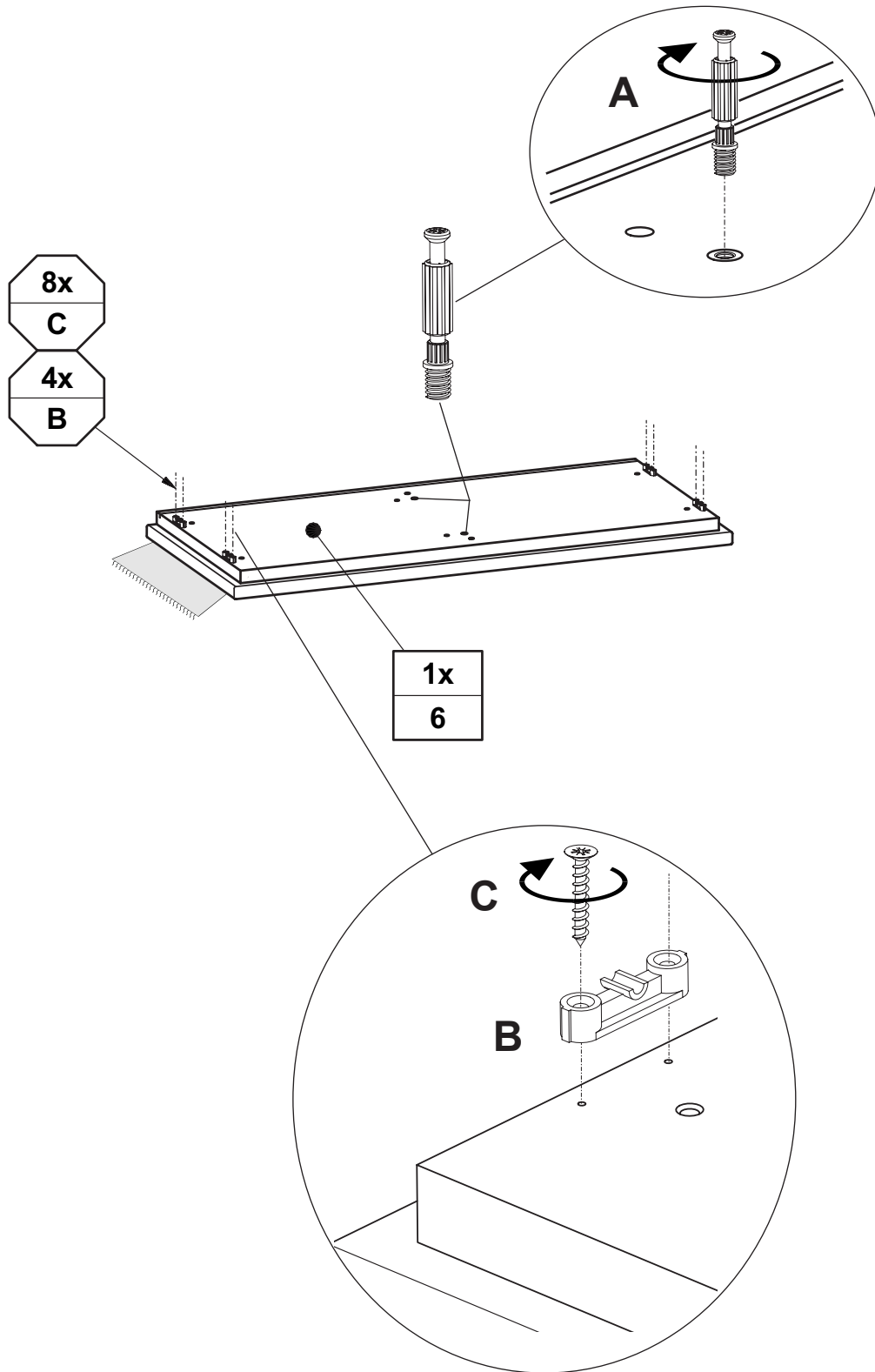

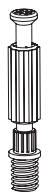
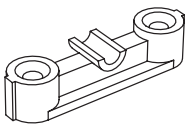

<p><b>A</b></p>  <p>2x 681 0759</p>	<p><b>B</b></p>  <p>4x 681 0886</p>	<p><b>C</b></p>  <p>3,5 x 20 8x 681 4888</p>
----------------------------------------------------------------------------------------------------------------------------	----------------------------------------------------------------------------------------------------------------------------	-----------------------------------------------------------------------------------------------------------------------------------------

# V8

## V8.1

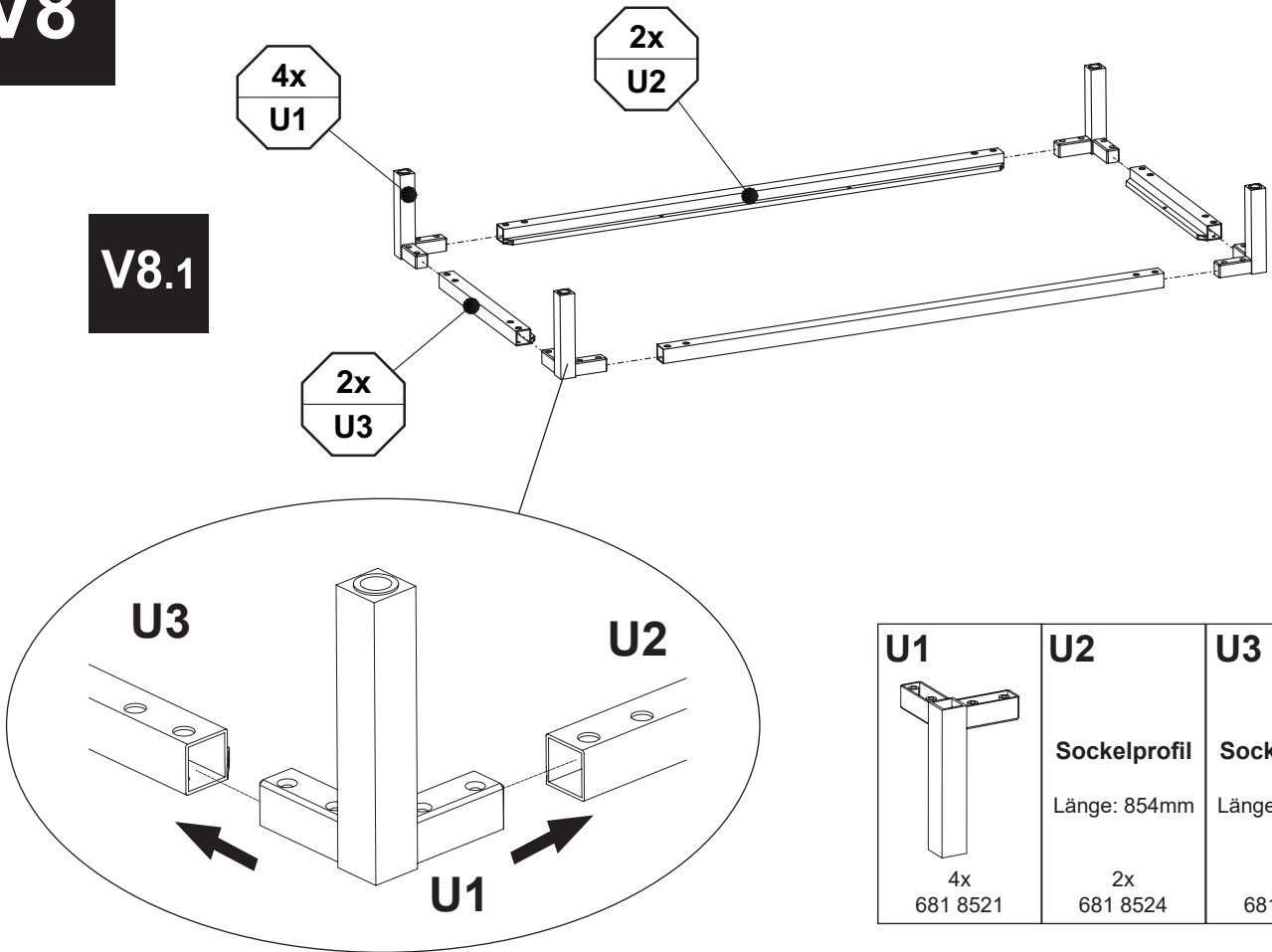

## V8.2

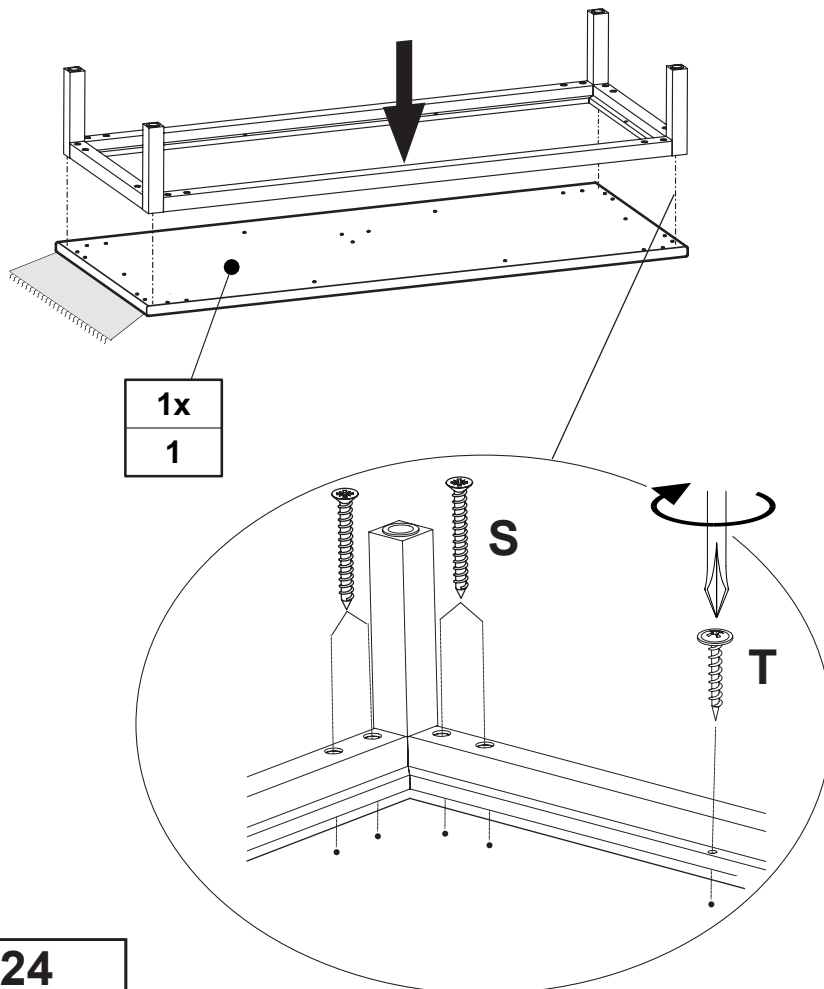



Höhenverstellung !!

1x G    1x H

V8.3

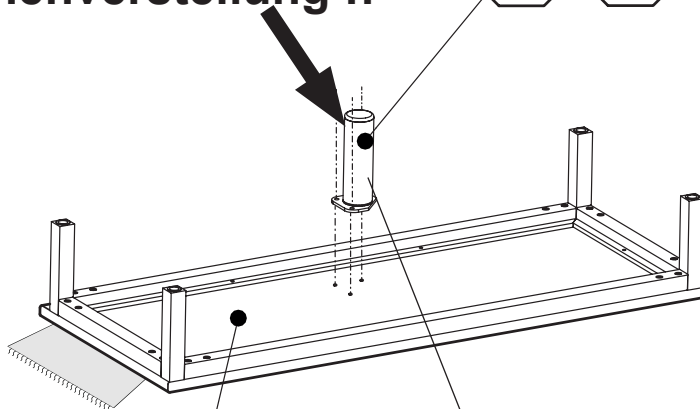

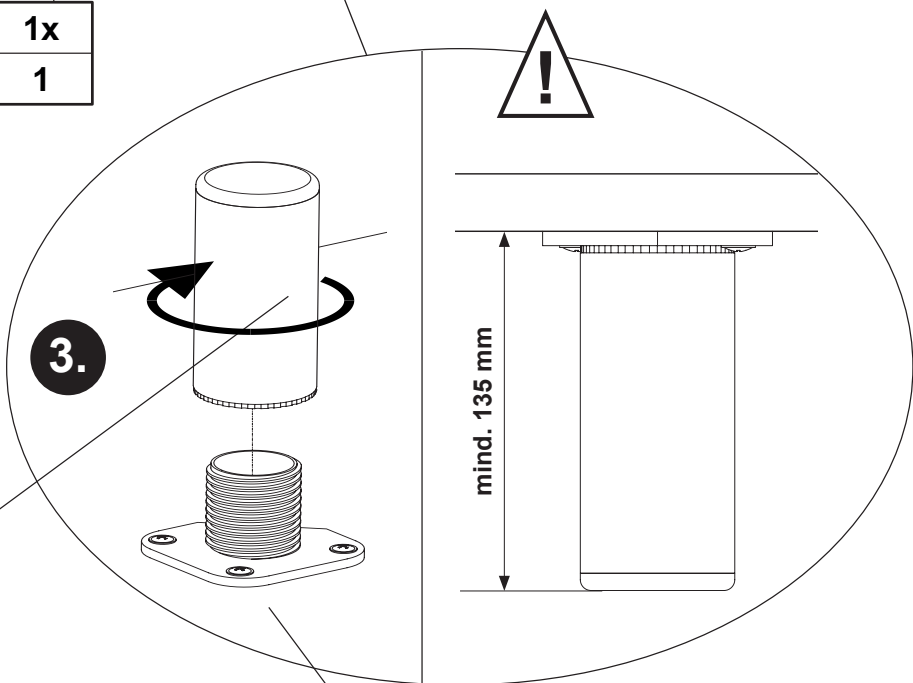

1x  
1

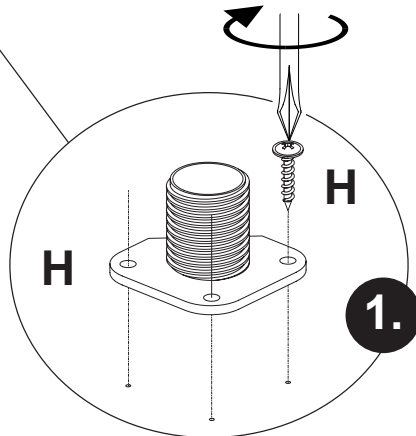
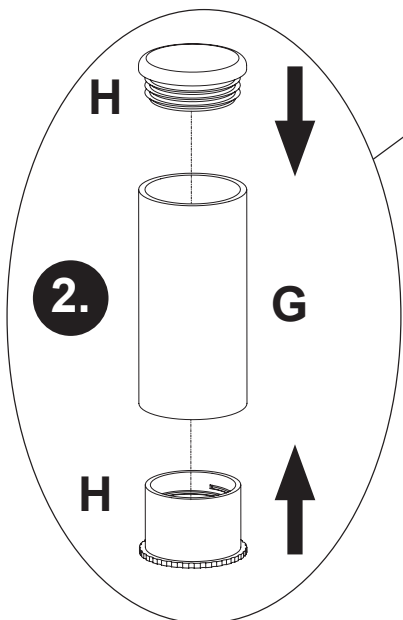

mind. 135 mm

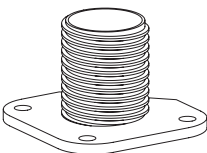
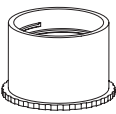

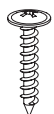
<p><b>G</b></p>  <p>1x 681 8533</p>	<p><b>H</b></p>  <p>1x</p>  <p>1x</p>  <p>1x</p>  <p>3x 4,0 x 17</p>
----------------------------------------------------------------------------------------------------------------------------	----------------------------------------------------------------------------------------------------------------------------------------------------------------------------------------------------------------------------------------------------------------------------------------------------------------------------------------------------------------------------------------------------------------------

## V8.4

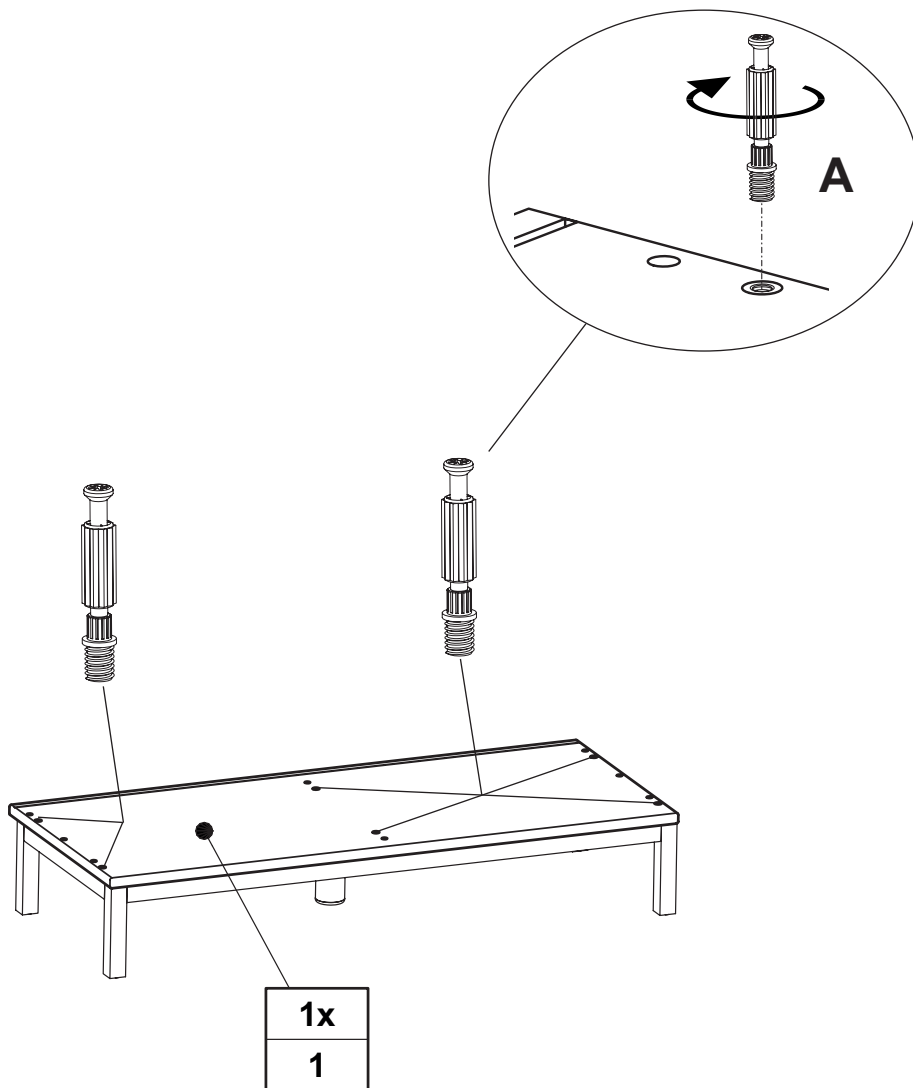

1x
1

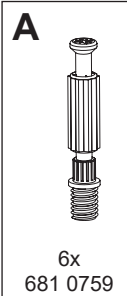

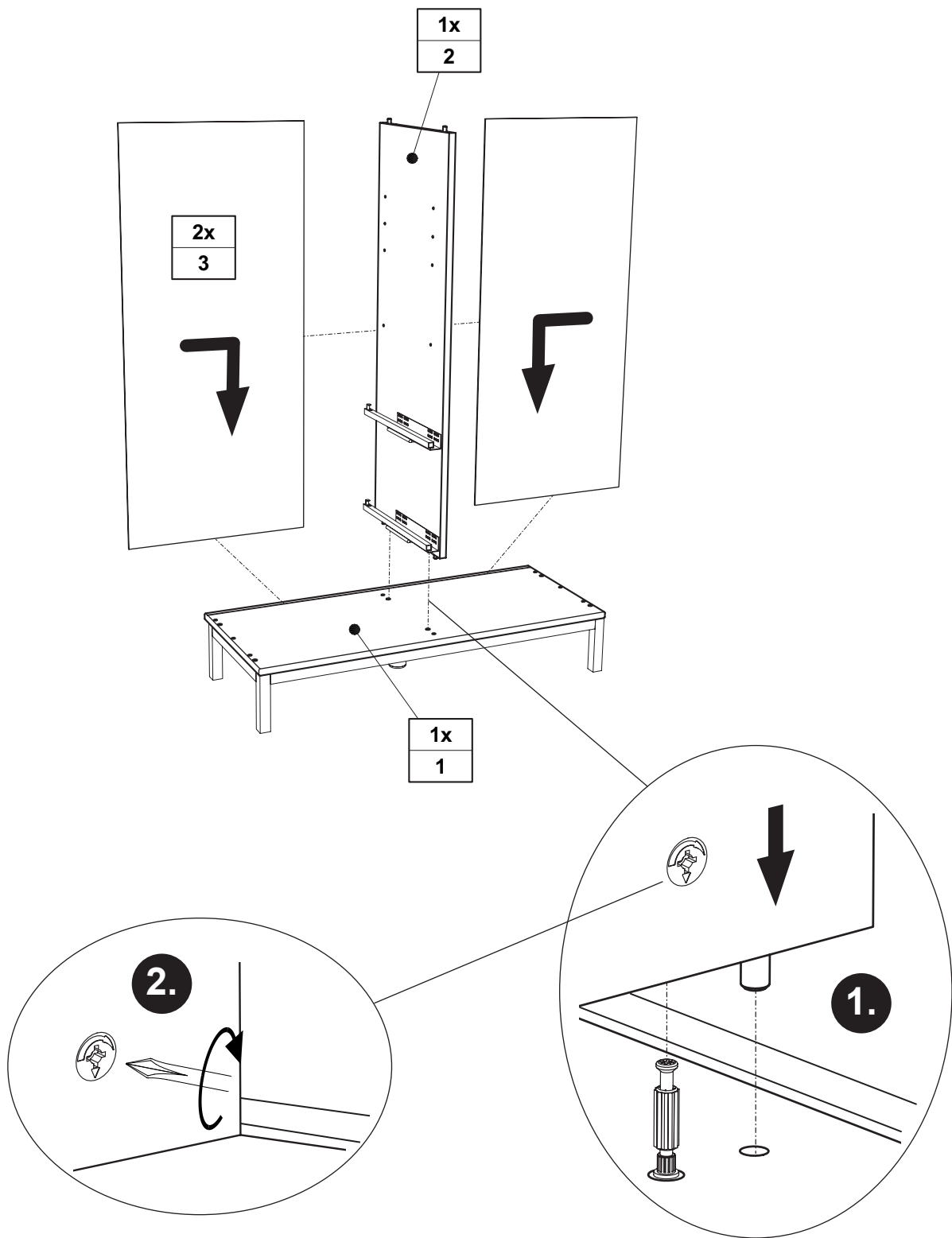

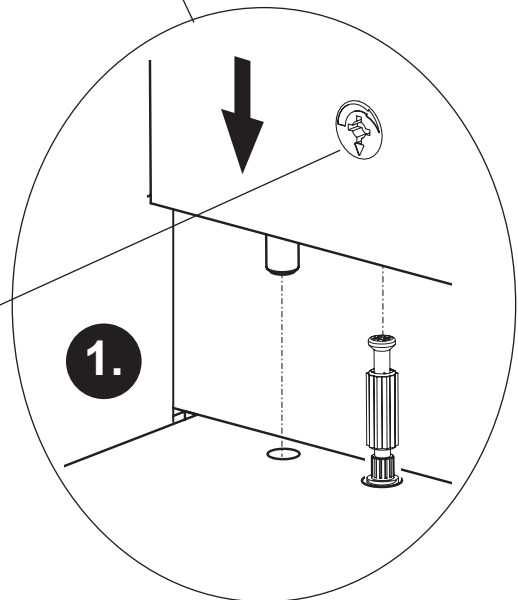
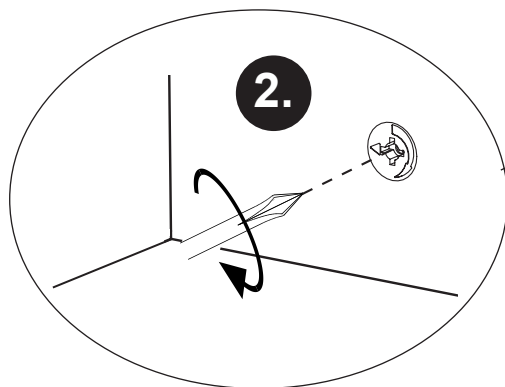
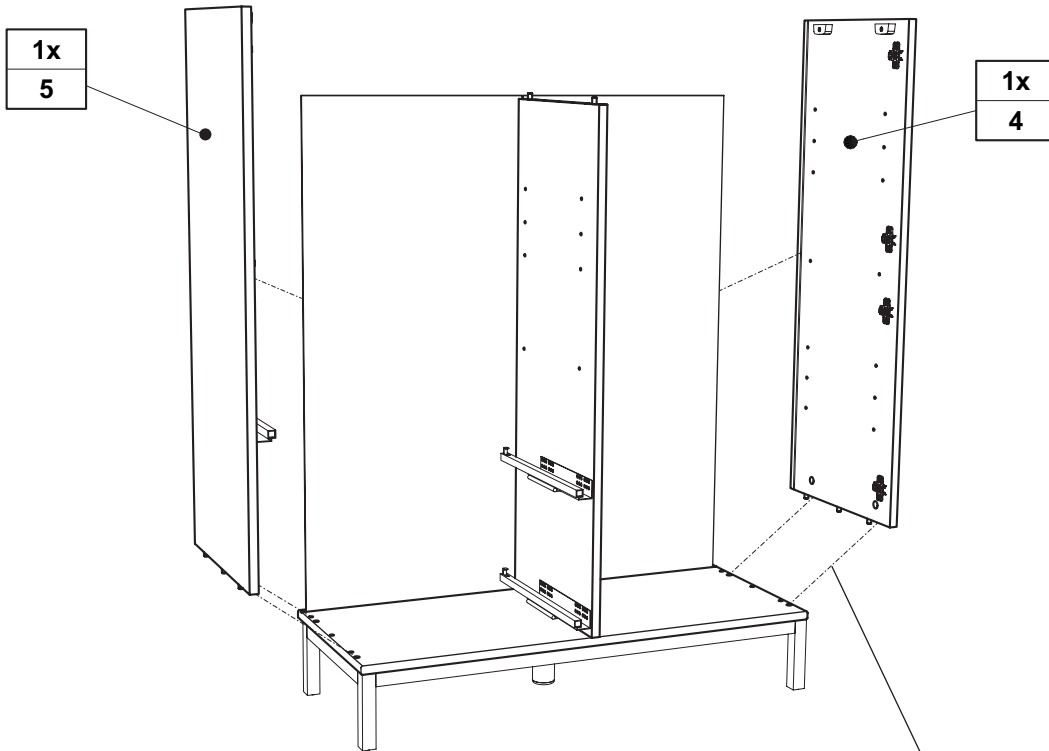



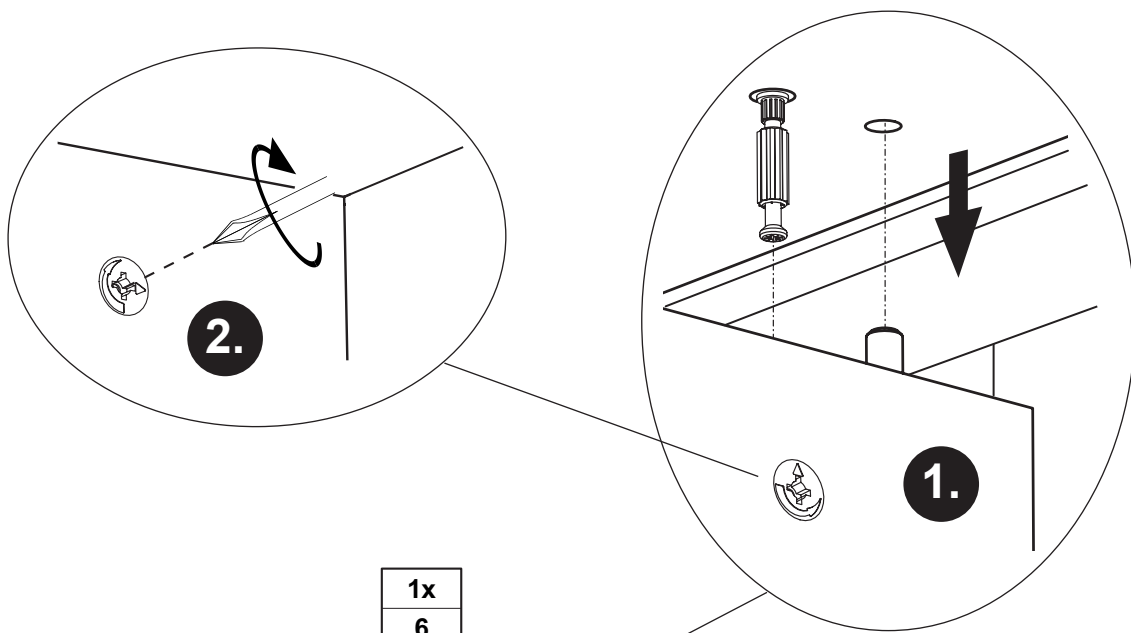

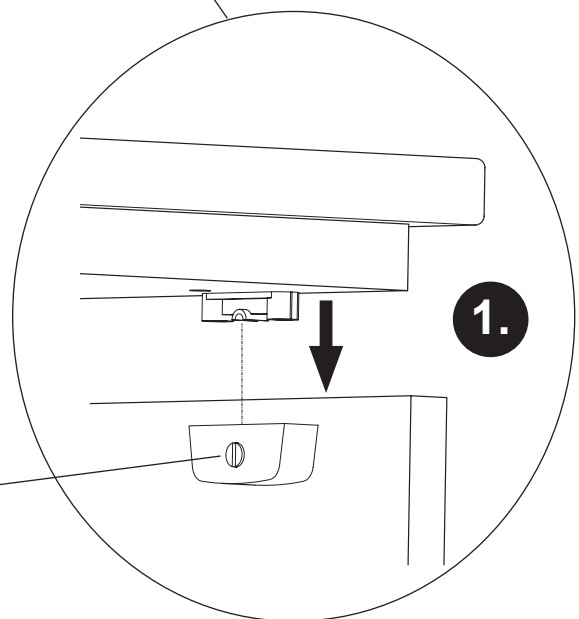
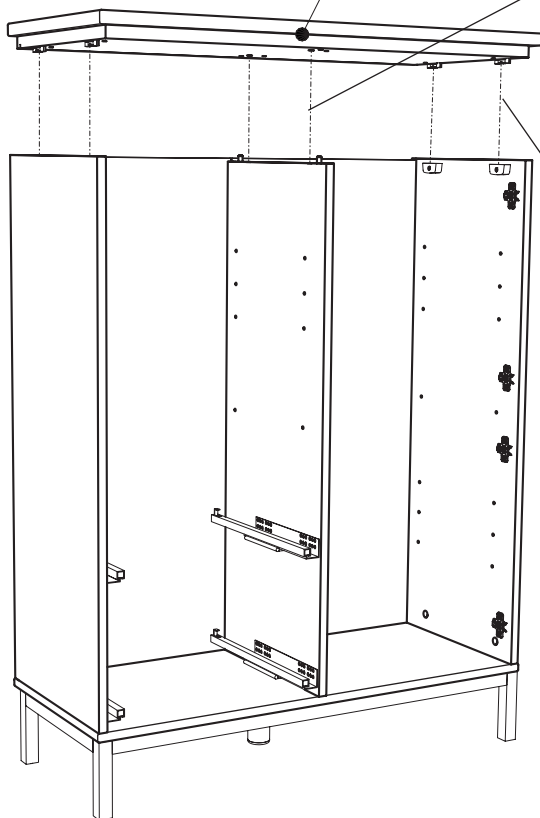

1x  
6



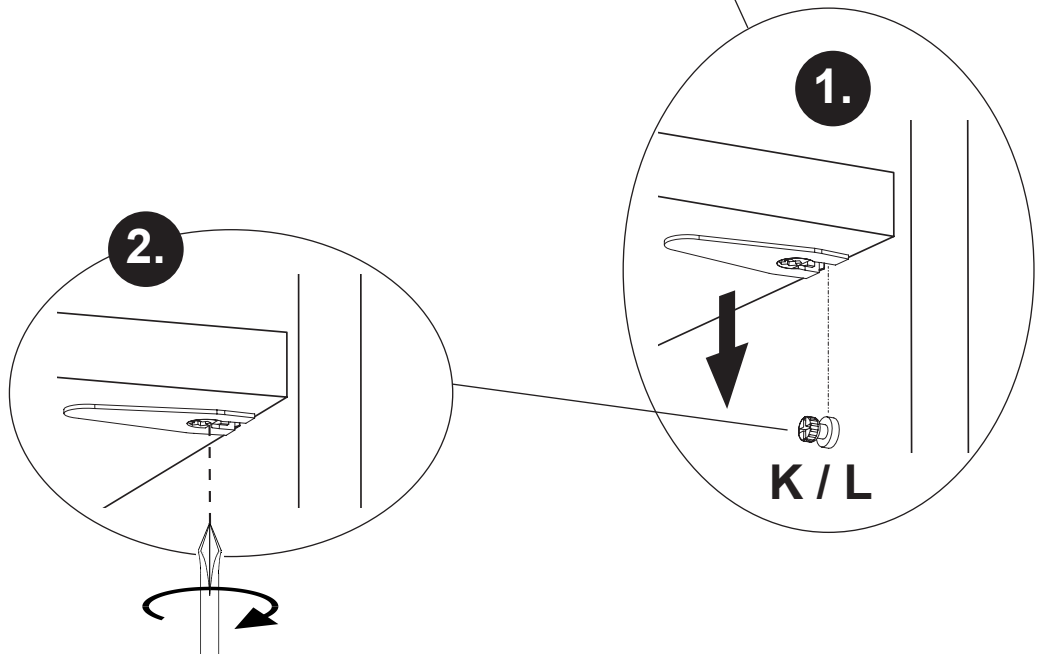
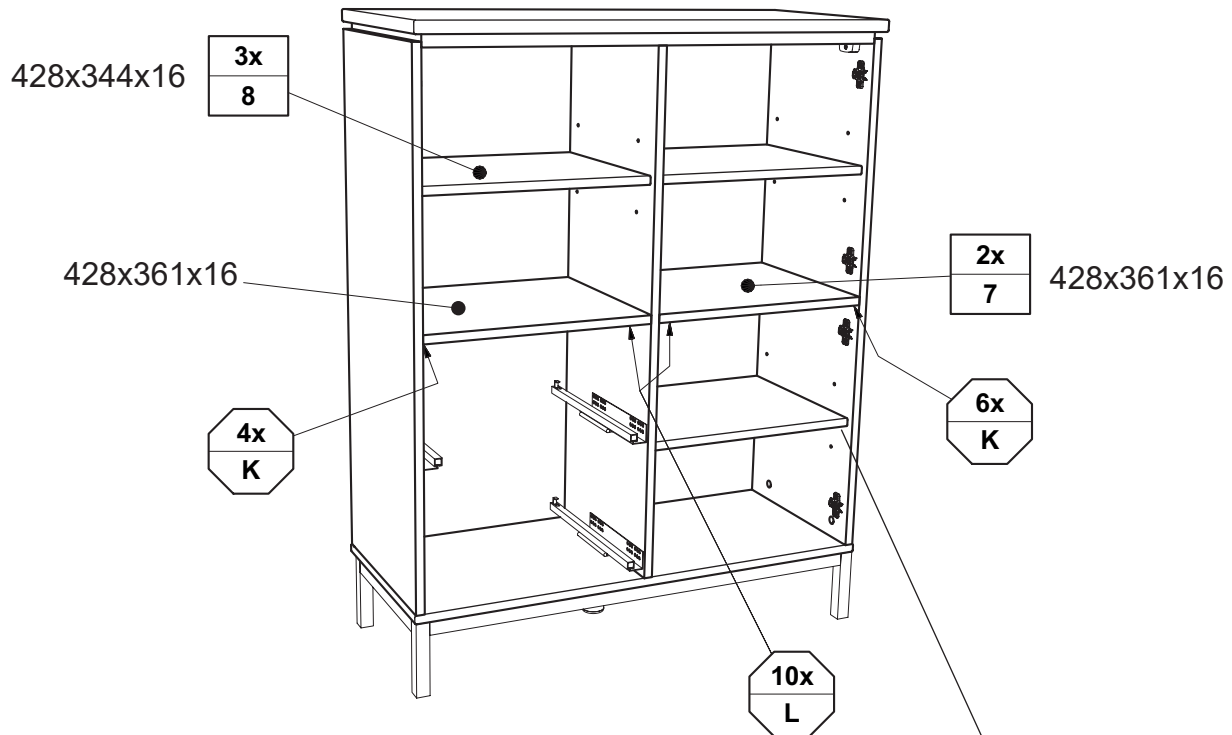

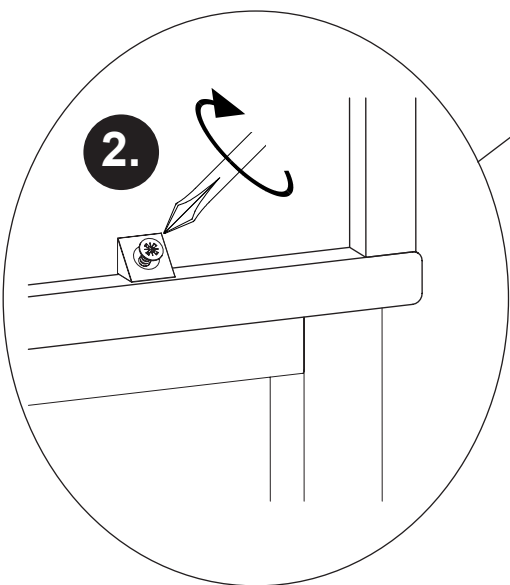
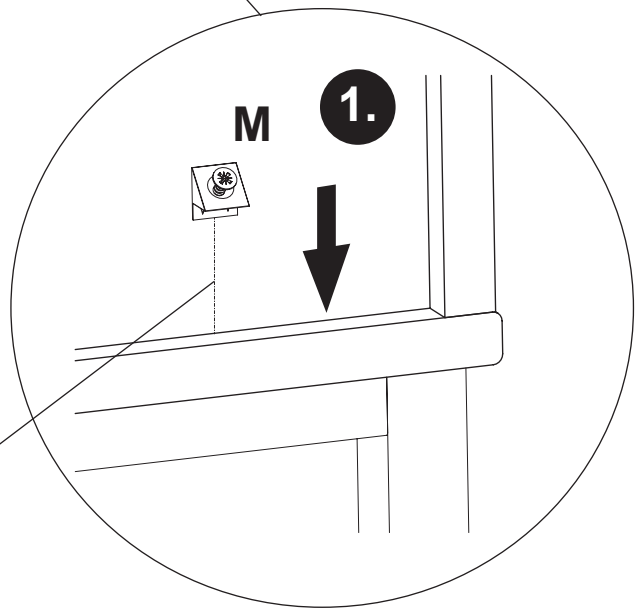
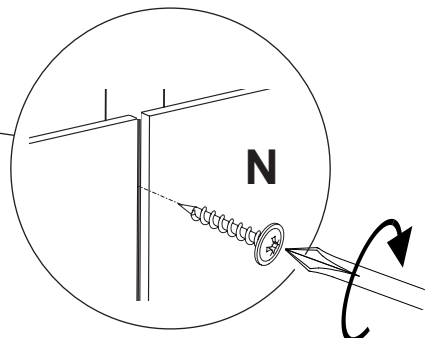
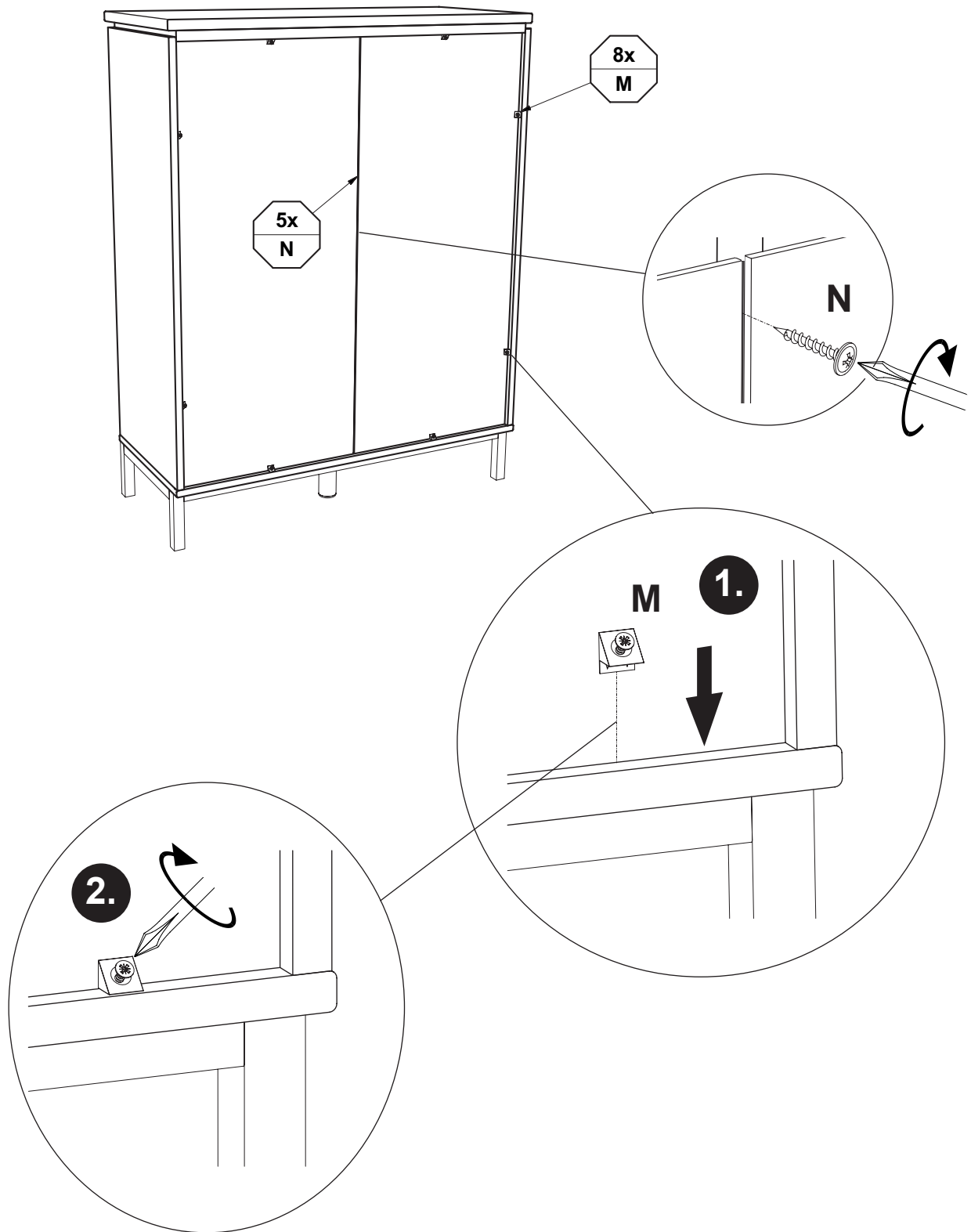
# M4



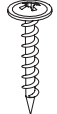

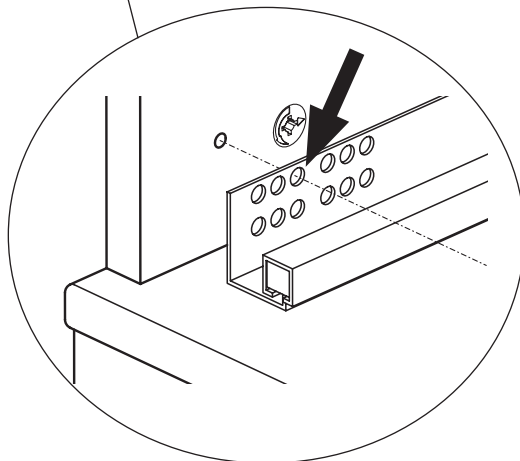
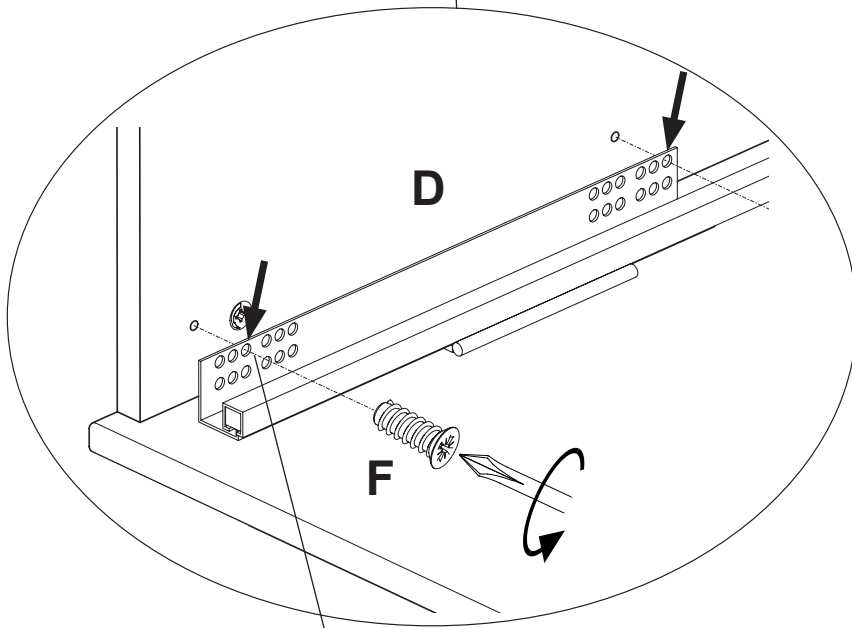
M	N
	
8x 681 2498	3,0 x 20 5x 681 4914

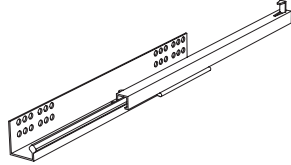

<b>D</b> 	<b>F</b> 
1x 681 3316	6,3 x 14 2x 681 5097

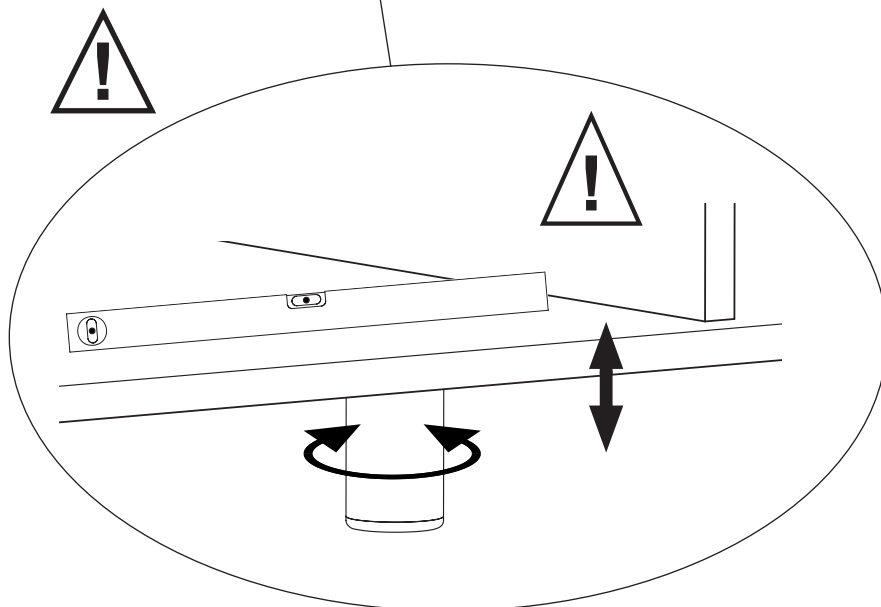
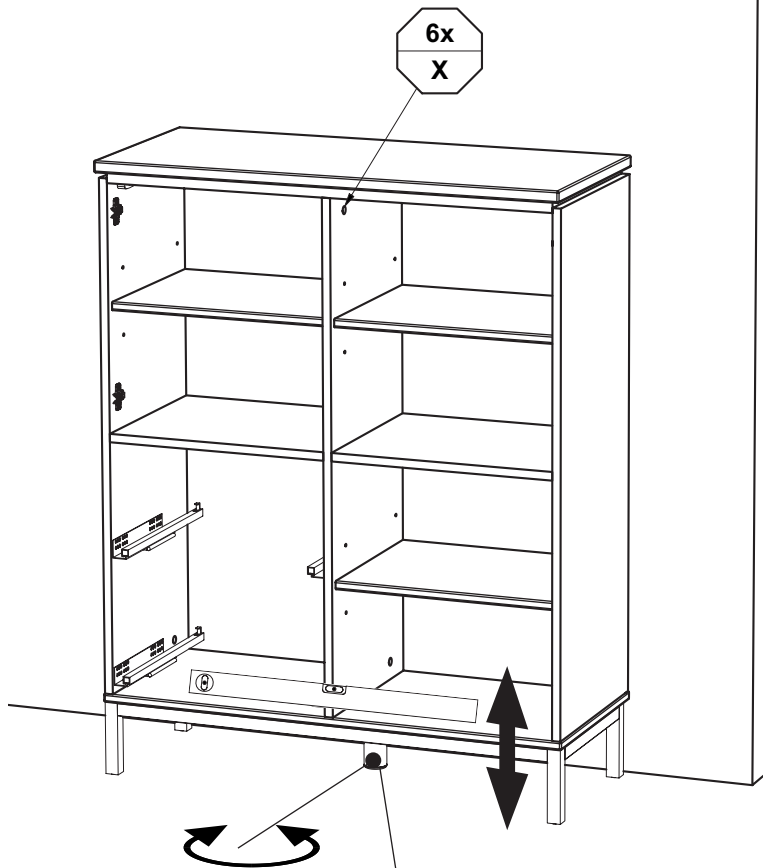

**Höhenverstellung !!**

X



Farbton  
Manhattan  
6x  
683 0102

# M8

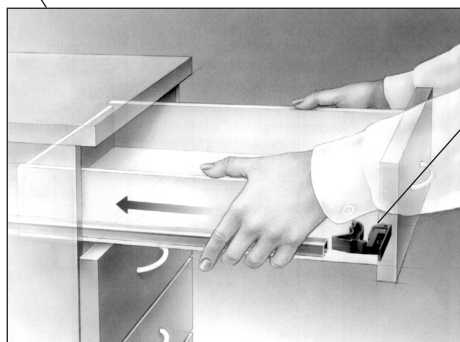
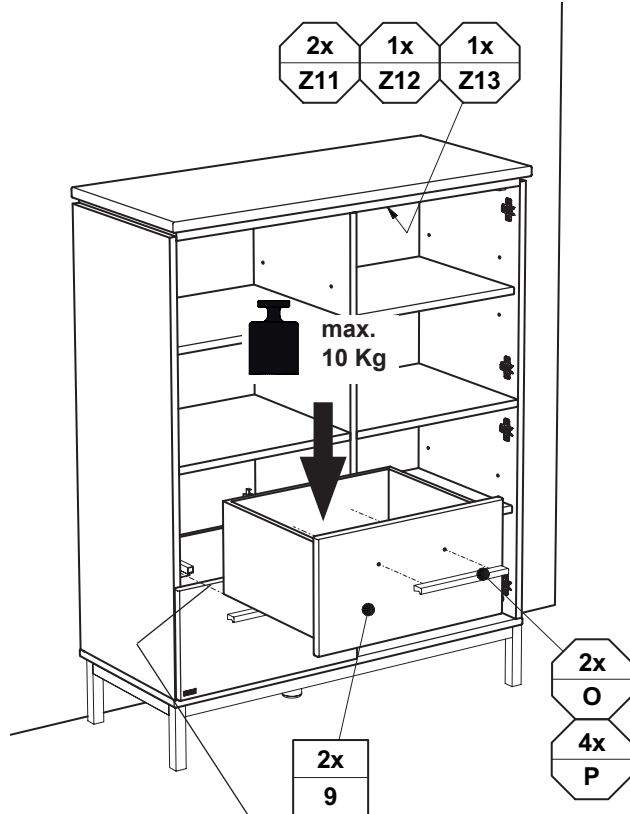

**CLICK !!**

<b>O</b>	<b>P</b>
<b>Griffstange</b>	
Länge: 210mm	
2x 681 8518	4,0 x 30 4x 681 4910

## Justierung der Schubkästen

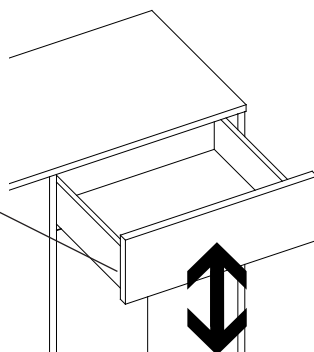
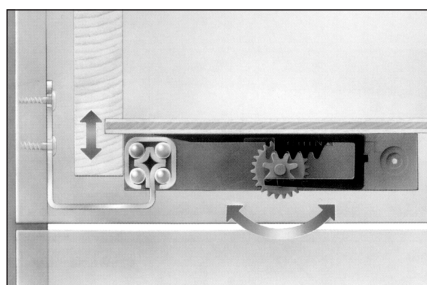
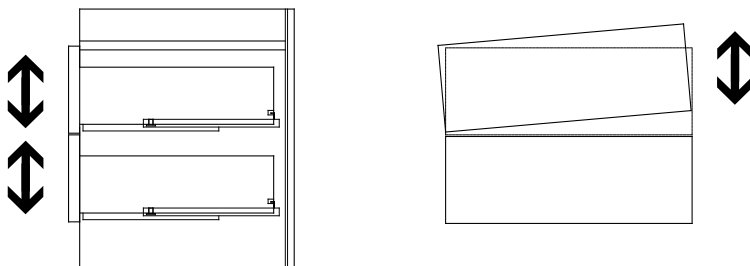

## Demontage der Schubkästen

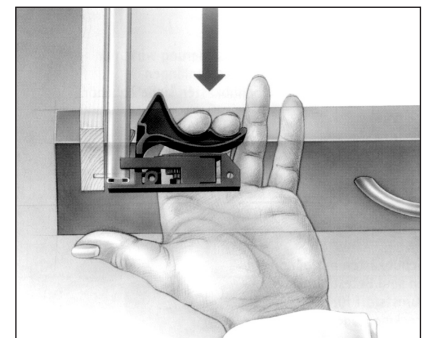

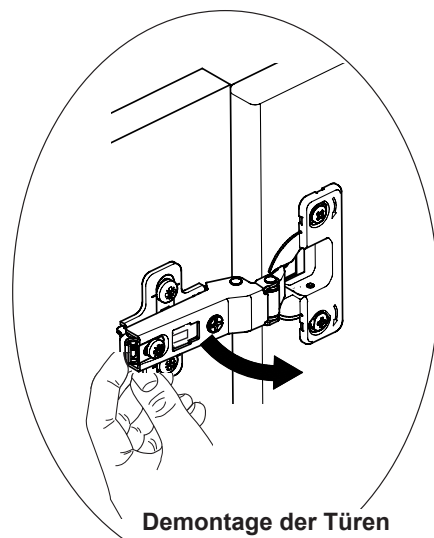
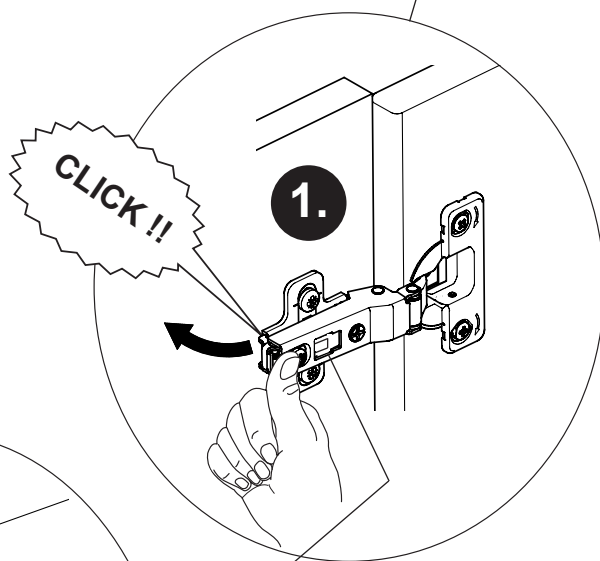
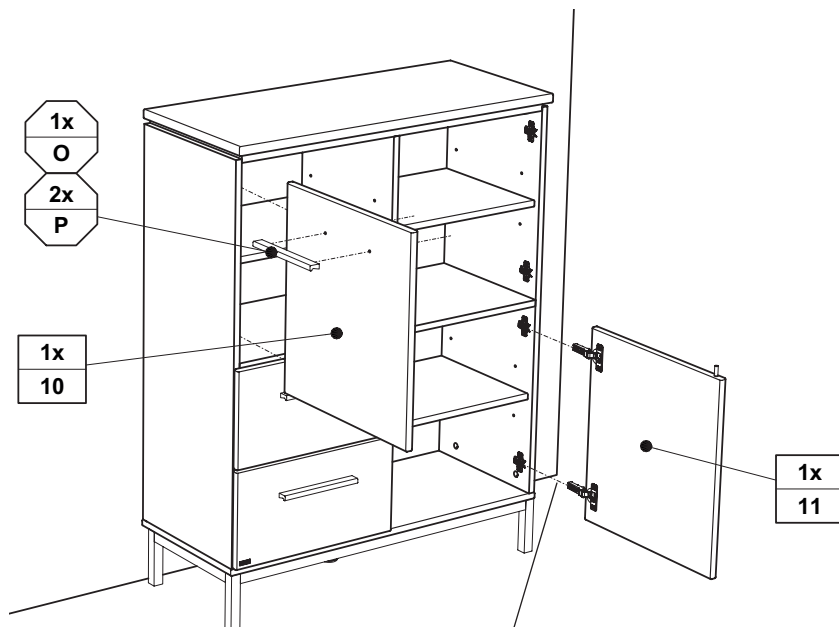

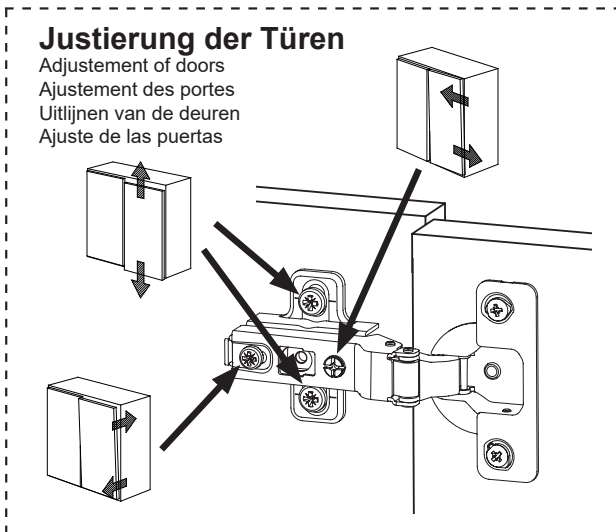
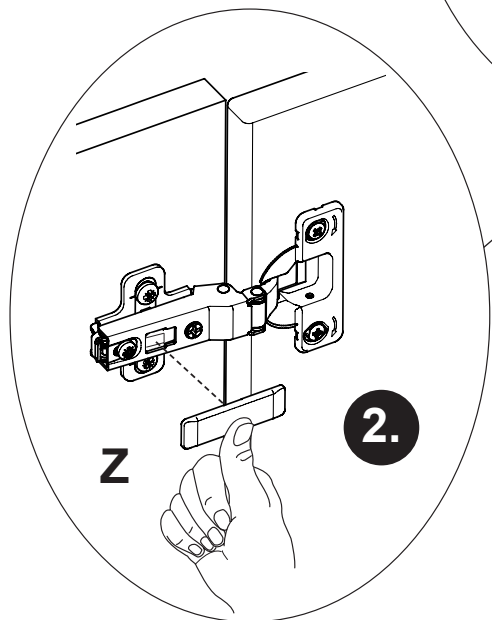

**Demontage der Türen**  
 dismantling the doors  
 Démontage des portes  
 demontage van de deuren  
 Desmontaje de las puertas

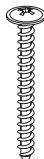

**Justierung der Türen**

Adjustement of doors  
 Ajustement des portes  
 Uitlijnen van de deuren  
 Ajuste de las puertas

<b>O</b>	<b>P</b>	<b>Z</b>
<b>Griffstange</b>		
Länge: 210mm		
1x 681 8518	4,0 x 30 2x 681 4910	4x 681 2552

# M10

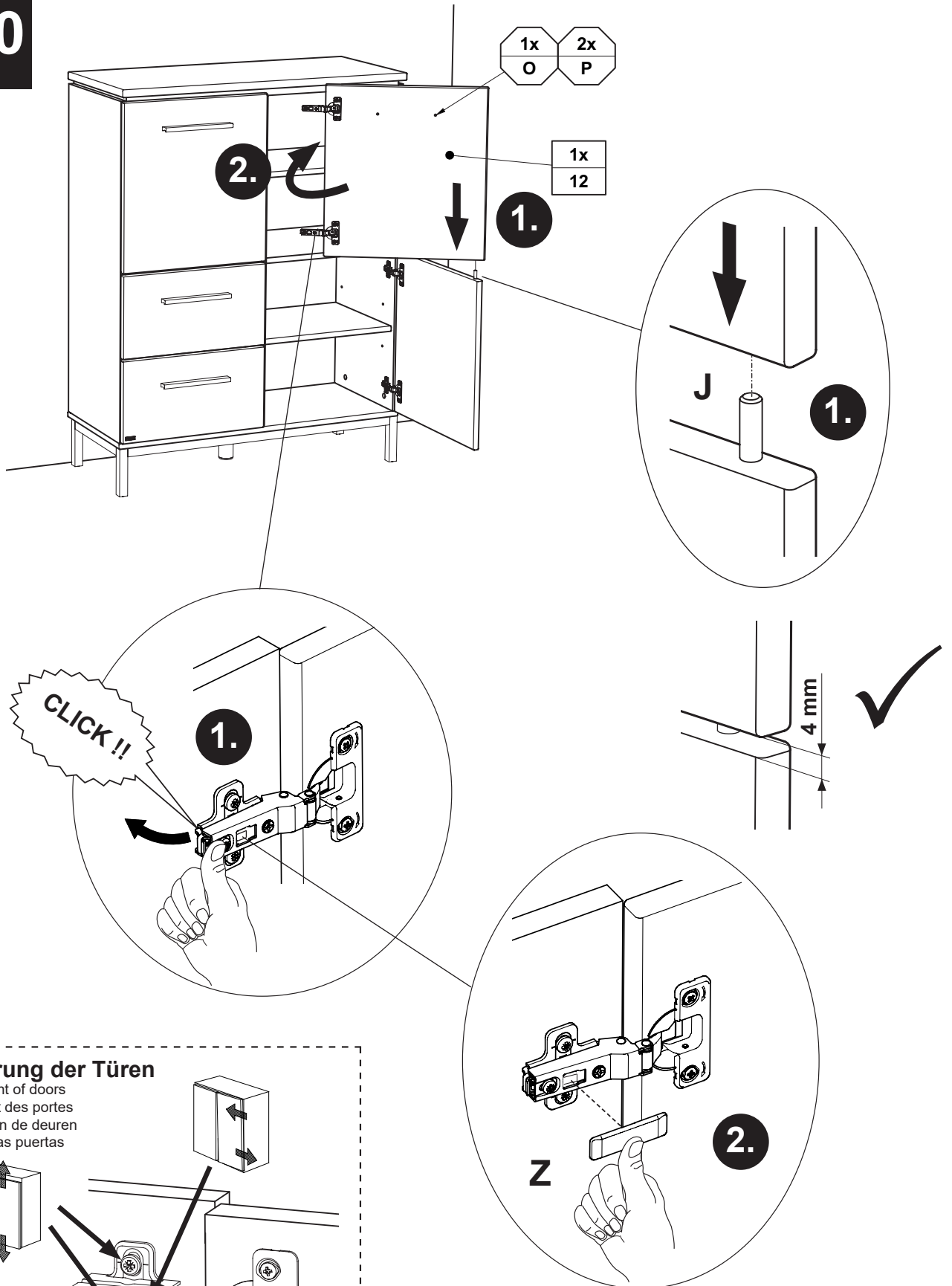

1x O  
2x P

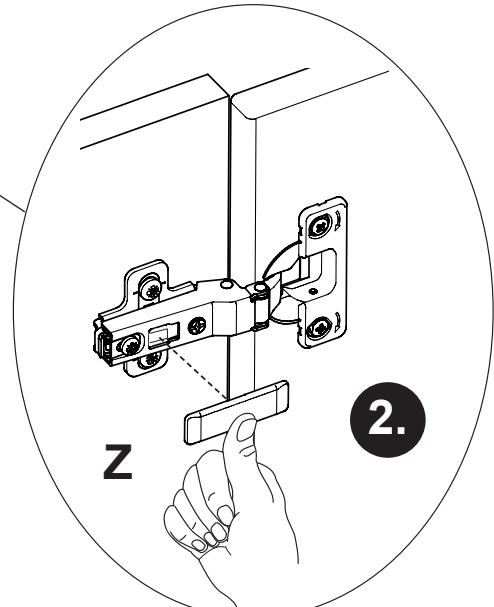
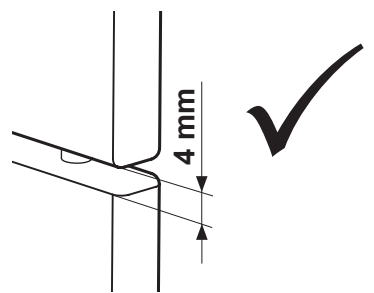
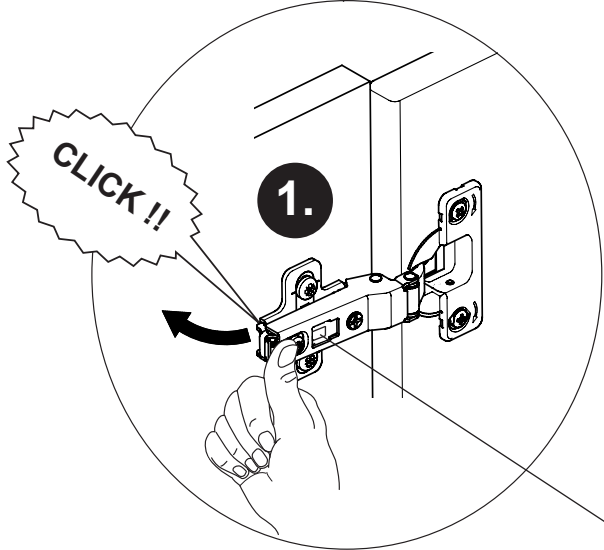

1x  
12

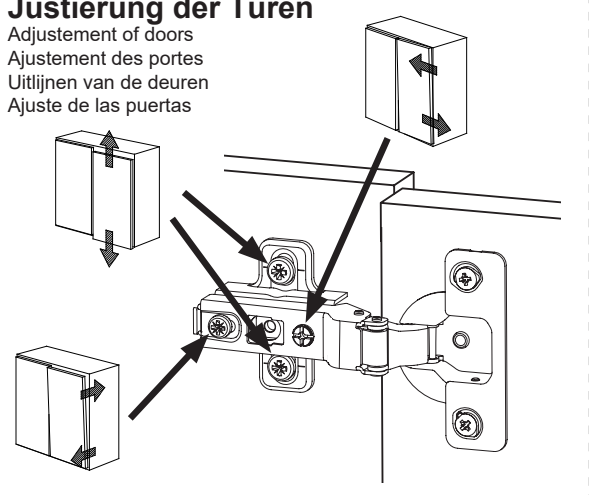

## Justierung der Türen

Adjustement of doors  
Ajustement des portes  
Uitlijnen van de deuren  
Ajuste de las puertas



O	P	Z
<b>Griffstange</b>		
Länge: 210mm	4,0 x 30	
1x	2x	2x
681 8518	681 4910	681 2552